

SC206-201

SC206-202

SC206-203

---

MANUAL PART NUMBER: 400-0453-002

## SC206-201/202/203

# PASSIVE AND ACTIVE UNBALANCED TO BALANCED AUDIO ADAPTERS USER'S GUIDE

# SPECIAL APPLICATIONS

## TABLE OF CONTENTS

	Page
PRECAUTIONS / SAFETY WARNINGS.....	2
GENERAL.....	2
INSTALLATION.....	2
CLEANING.....	2
FCC NOTICE .....	2
ABOUT YOUR SC206-201/202/203 .....	3
TECHNICAL SPECIFICATIONS .....	3
PRODUCT DESCRIPTION .....	5
APPLICATION DIAGRAMS.....	6
DIAGRAM 1: TYPICAL SETUP .....	6
DIAGRAM 2: INTERNAL VIEW .....	7
INSTALLING YOUR SC206-201/202/203.....	8
OPERATION.....	8
TROUBLESHOOTING GUIDE.....	8
THE LED IS NOT ON (SC206-203 ONLY).....	8
THERE IS NO REMOTE SOUND .....	8
ALTINEX POLICIES .....	8
LIMITED WARRANTY/RETURN POLICIES .....	8
CONTACT INFORMATION .....	8

## PRECAUTIONS / SAFETY WARNINGS 1

Please read this manual carefully before using your **SC206-201/202/203**. Keep this manual handy for future reference. These safety instructions are to ensure the long life of your **SC206-201/202/203** and to prevent fire and shock hazards. Please read them carefully and heed all warnings.

### 1.1 GENERAL

- Qualified ALTINEX service personnel or their authorized representatives must perform all service.

### 1.2 INSTALLATION

- To prevent fire and shock, do not expose this unit to water or moisture. Do not place the **SC206-201/202/203** in direct sunlight, near heaters or heat-radiating appliances, or near any liquid. Exposure to direct sunlight, smoke, or steam can harm internal components.
- Handle the **SC206-201/202/203** carefully. Dropping or jarring can damage the unit.
- Do not pull any cables that are attached to the **SC206-201/202/203**.

### 1.3 CLEANING

- Clean only with a dry cloth. Never use strong detergents or solvents, such as alcohol or thinner. Do not use a wet cloth or water to clean the unit. Do not open the unit to clean.

### 1.4 FCC NOTICE

- This device complies with Part 15 of the FCC Rules. Operation is subject to the following two conditions: (1) This device may not cause harmful interference, and (2) this device must accept any interference received, including interference that may cause undesired operation.

- This equipment has been tested and found to comply with the limits for a Class A digital device, pursuant to Part 15 of the FCC Rules. These limits are designed to provide reasonable protection against harmful interference when the equipment is operated in a commercial environment. This equipment generates, uses, and can radiate radio frequency energy and, if not installed and used in accordance with the instructions found herein, may cause harmful interference to radio communications. Operation of this equipment in a residential area is likely to cause harmful interference in which case the user will be required to correct the interference at his own expense.
- Any changes or modifications to the unit not expressly approved by ALTINEX, Inc. could void the user's authority to operate the equipment.

## ABOUT YOUR SC206-201/202/203 2

### SC206-201/202/203 PASSIVE and ACTIVE UNBALANCED to BALANCED AUDIO ADAPTERS

The **SC206-201**, **SC206-202**, and **SC206-203** are audio adapters that convert unbalanced audio signals to balanced audio. The converted signals provide better sound quality and greatly reduce noise over long transmission lengths. The **SC206-201** and **SC206-202** are passive devices and may be used to convert balanced signals to unbalanced signals as well.

The **SC206-201** is designed to convert a standard computer audio output to balanced audio. It has excellent bandwidth and is ideal for most commercial-user applications. Since the **SC206-201** is a passive device, there is no need for an external power source. Simply make the audio connections and it is ready to go.

The **SC206-202** is also a passive device and is designed to convert unbalanced audio output from computers, DVD players, VCRs, etc. to balanced audio. The **SC206-202** possesses superior bandwidth, and is perfect for home theaters and marketing/sales presentation applications.

The **SC206-203** is an active unbalanced-balanced converter and requires an external power source. This unit is designed for high-performance audio applications requiring professional quality sound.

## TECHNICAL SPECIFICATIONS 3

Specifications are subject to change.  
See [www.altinex.com](http://www.altinex.com) for up-to-date information.

FEATURES/ DESCRIPTION	SC206-201/202/203
<b>Inputs</b>	
Audio	Wire lead (3)
Power (-203 only)	Wire lead (2)
<b>Output</b>	
Audio	5-pin terminal block male (1)
<b>Compatibility</b>	
SC206-201	Standard PC Application
SC206-202	Home Theater
SC206-203	High-Performance
<b>Accessories Included</b>	
Output mating connector	5-pin terminal block female (1)

Table 1. **SC206-201/202/203** General

MECHANICAL	SC206-201/202/203
Material	FP-301 tubing
Color	Clear
Height	0.75 in (19.1 mm)
Width	1.25 in (31.8 mm)
Depth	2.50 in (63.5 mm)
Weight	0.15 lb (0.07 kg)
T° Operating	10°C to 40°C
T° Maximum	0°C to 50°C
Humidity	90% non-condensing
MTBF (calculations)	40,000 hrs

Table 2. **SC206-201/202/203** Mechanical

ELECTRICAL		SC206-201/202/203
<b>Input Signals</b>		
SC206-201: Impedance	600 ohms	
Max Level	3 dBu	
SC206-202: Impedance	500 ohms	
Max Level	3 dBu	
SC206-203: Impedance	10 kohms	
Max Level	0 dBu	
<b>Output Signals</b>		
SC206-201: Gain*	0 dB +/- 0.3dB	
Impedance	600 ohms	
Response	200Hz-15kHz	
Max Power	100mW	
SC206-202: Gain*	0 dB +/- 0.3dB	
Impedance	1300 ohms	
Response	20Hz-20kHz	
Max Power	100mW	
SC206-203: Gain*	7 dB +/- 0.3dB	
Impedance	600 ohms	
Response	10Hz-25kHz	
Max Power	100mW	
<b>Power Consumption</b>	(from +9 VDC source)	
SC206-203 only	40 mA (0.36 W)	

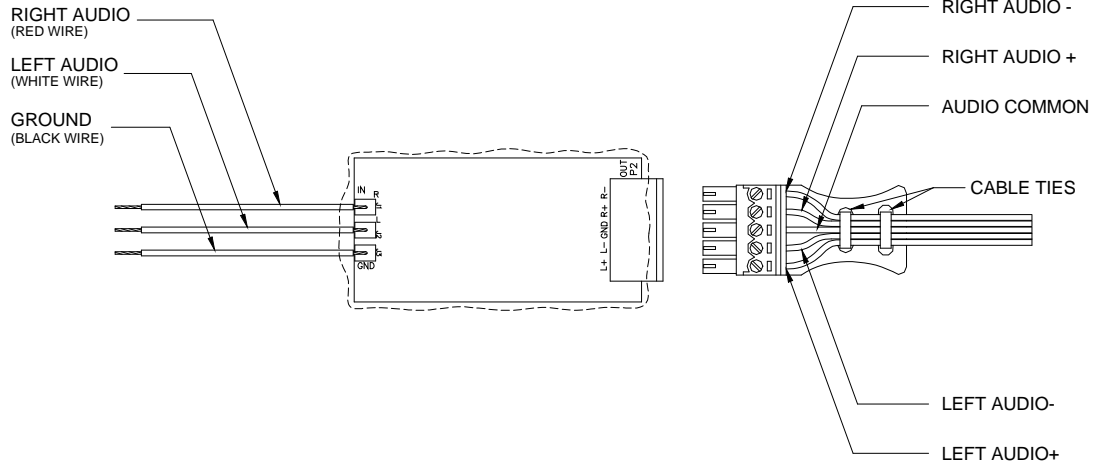
Table 3. **SC206-201/202/203** Electrical

\* The gain is as measured at the output of a high impedance differential receiver.

AUDIO INPUT

**SC206-201 and  
SC206-202**

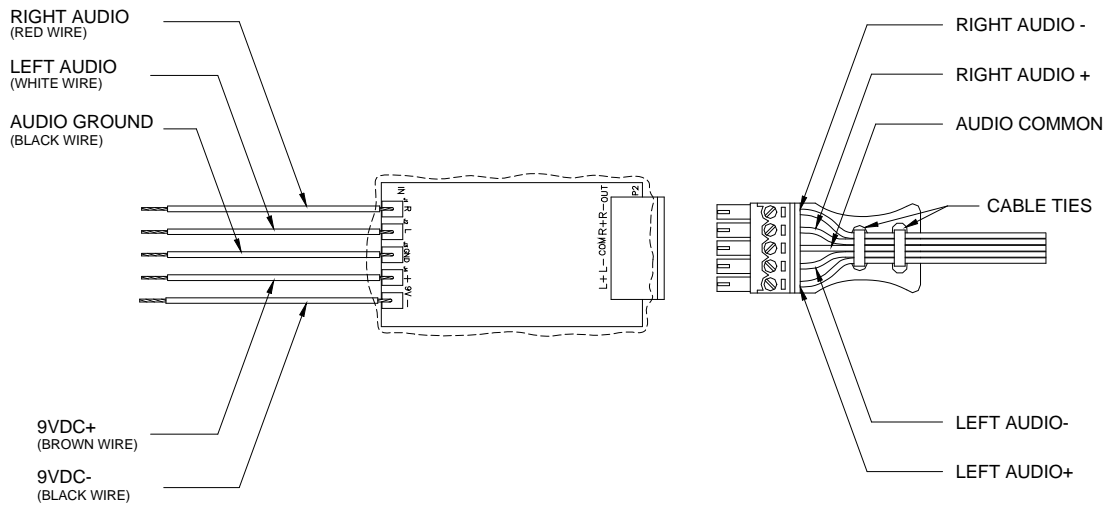
AUDIO OUTPUT



AUDIO INPUT

**SC206-203**

AUDIO OUTPUT

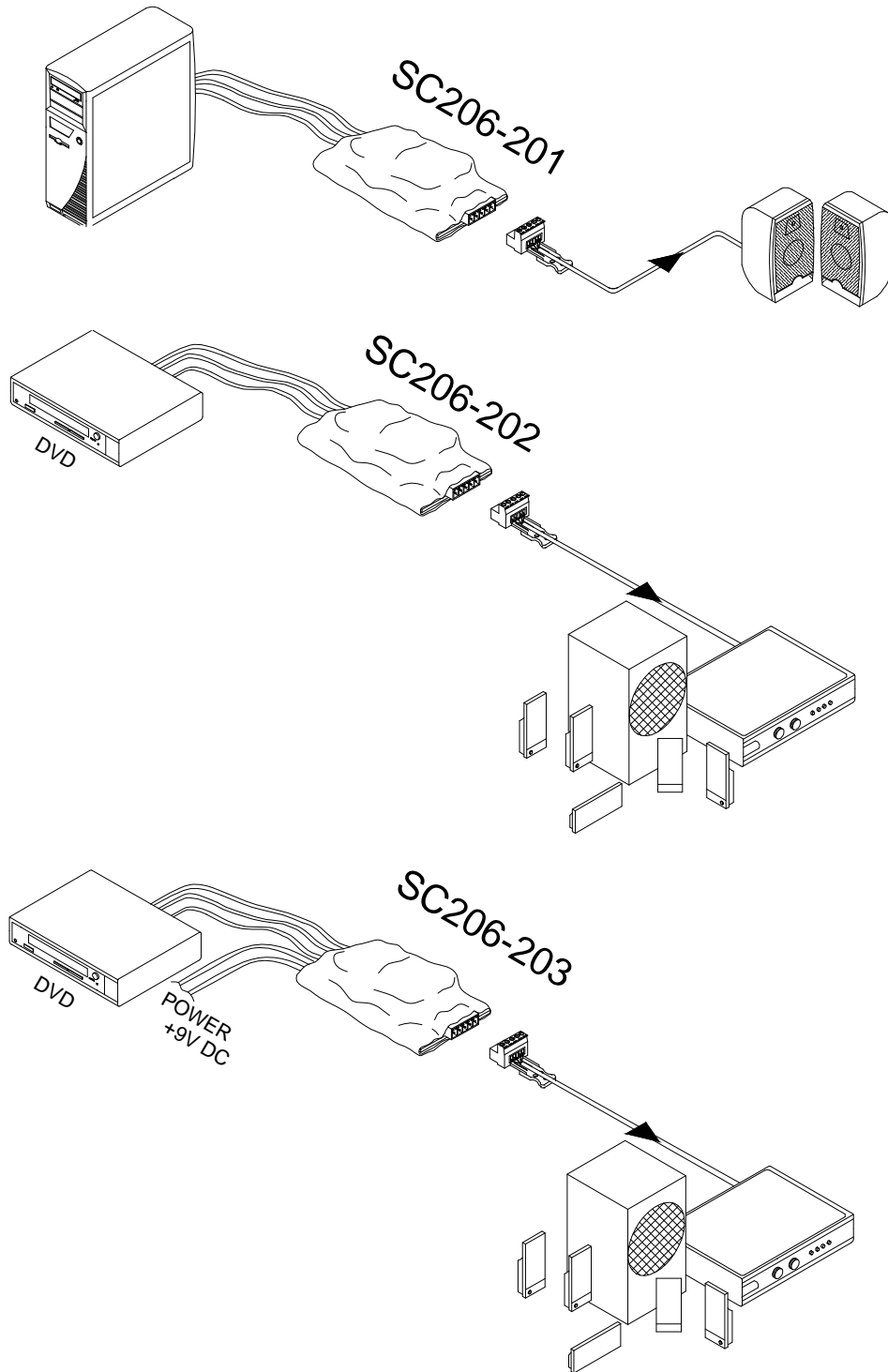


POWER

## APPLICATION DIAGRAMS

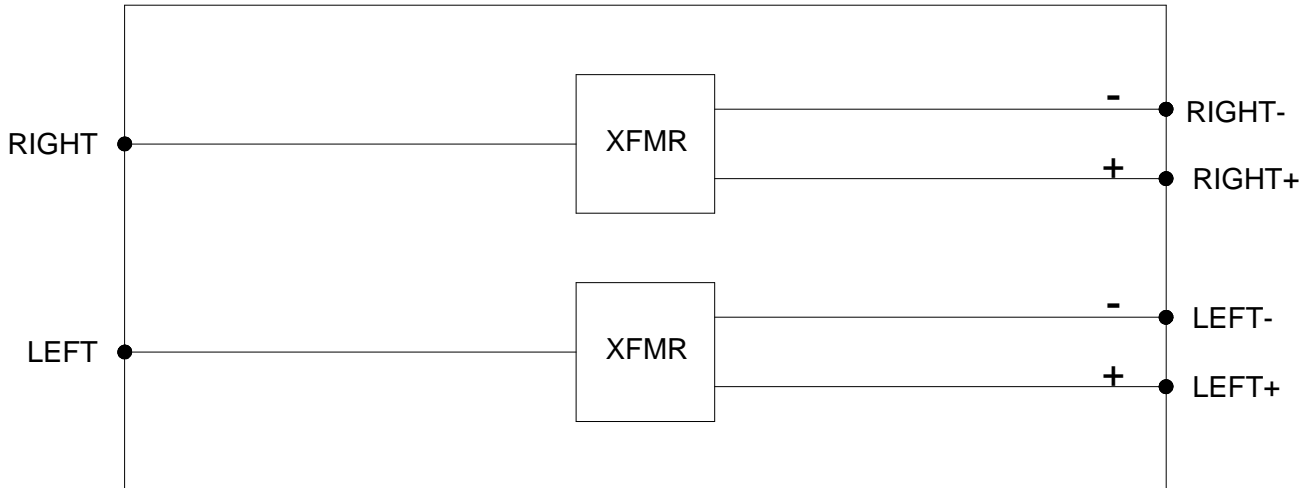
5

### DIAGRAM 1: TYPICAL SETUP

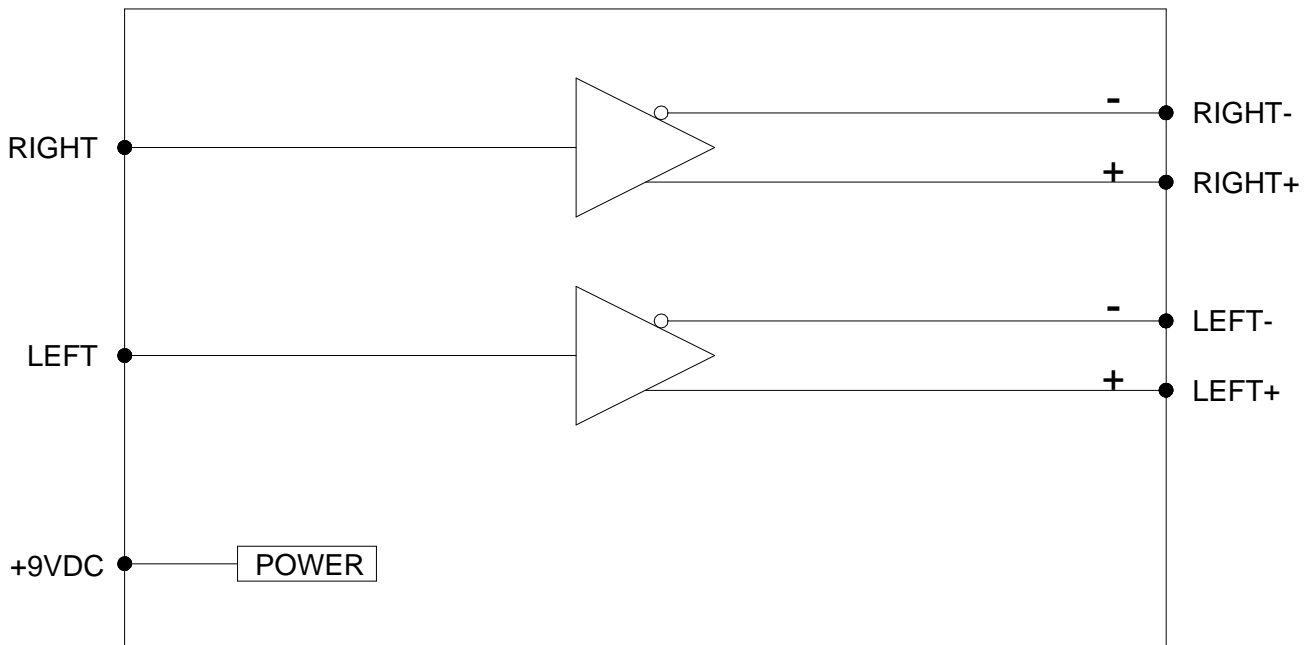


**DIAGRAM 2: INTERNAL VIEW**

## SC206-201/202



## SC206-203





## INSTALLING YOUR SC206-201/202/203 6

**Step 1.** Connect the wire leads on the input side of the **SC206-201/202/203** to the output of the audio source. The audio source could be a sound card, VCR, DVD player etc.

Use the Description diagrams for wiring and pinout information.

**Step 2.** Wire the audio cables from the receiving device (amplifier, speakers etc.) to the terminal block connectors provided with the unit.

**Step 3.** Connect the terminal block connector to the output of the **SC206-201/202/203**.

**Step 4.** Turn on the +9VDC power to the **SC206-203**. The **SC206-201** and **SC206-202** do not require a power supply.

**Step 5.** The adapter is now operational. Verify the sound quality on the receiving end is equivalent to the input source.

## OPERATION 7

The **SC206-201/202/203** requires no adjustments for optimum performance. Once set up, the **SC206-201/202/203** will work trouble-free without user intervention.

## TROUBLESHOOTING GUIDE 8

We have carefully tested and found no problems in the supplied **SC206-201/202/203**. However, we would like to offer suggestions for the following:

### 8.1 THE LED IS NOT ON (SC206-203 only)

**Cause 1: There is no power.**

*Solution:* Verify the **SC206-203** is connected to a +9VDC power adapter.

*Solution 2:* Make sure the power adapter is plugged into a working outlet.

**Cause 2: The cables are loose.**

*Solution:* Verify the power connector from the AC adapter is securely attached to the **SC206-203**.

**Cause 3: The SC206-203 has a problem.**

*Solution:* If there is still no power, the **SC206-203** may require service. Please call ALTINEX at (714) 990-2300.

### 8.2 THERE IS NO REMOTE SOUND

**Cause 1: The source has a problem.**

*Solution:* Connect the output of the PC directly to the speakers and verify the quality is good. If the sound is good, see Cause 2.

**Cause 2: The cable connections are wrong.**

*Solution:* Verify the input of the **SC206-201/202/203** is connected to the output of the source and that the output is properly wired to the receiving device.

*Solution 2:* Remove the **SC206-201/202/203** from the setup, but connect the source to the receiver using all the same cables.

*Solution 3:* If there is still no sound, there may be a problem with the **SC206-201/202/203**. Please call ALTINEX at (714) 990-2300.

## ALTINEX POLICIES 9

### 9.1 LIMITED WARRANTY/RETURN POLICIES

Please see the ALTINEX website at [www.altinex.com](http://www.altinex.com) for details on warranty and return policies.

### 9.2 CONTACT INFORMATION

**ALTINEX, Inc.**

592 Apollo Street

Brea, CA 92821 USA

**TEL:** 714 990-2300

**TOLL FREE:** 1-800-ALTINEX

**WEB:** [www.altinex.com](http://www.altinex.com)

**E-MAIL:** [solutions@altinex.com](mailto:solutions@altinex.com)